

Salt crystallization tests: Focus on their objective

A. Elena Charola^{1*}, Inge Rørig-Dalgaard², Jacek Chwast³ and Jan Elsen³

¹ Museum Conservation Institute, Smithsonian Institution, Washington, DC, USA

² DTU, Department of Civil Engineering, Group of Construction Materials, Lyngby, Denmark

³ KU Leuven, Department of Earth and Environmental Sciences, Leuven, Belgium

* charolaa@si.edu

Abstract

Many factors influence the durability of a building material, such as its mechanical resistance, exposure conditions and the presence of soluble salts in it. Since the latter interact with each other, it is difficult to relate any of them to the specific damage observed. Lubelli et al.¹ have recently summarized the shortcoming of some salt crystallization tests and of the mathematical models based on the accepted salt crystallization theories. The net result is that there is no single salt crystallization test that can provide all answers since crystallization kinetics, depending on specific circumstances, play a critical role in the induced deterioration. Nonetheless, specific tests have been developed which have proved to be practically viable in assessing particular material compatibility or potential damaging sources. Two such tests are described, one using sodium chloride to determine compatibility of restoration mortars, and another where the efflorescence of gypsum for brick masonry is evaluated. These methods have proven their reliability and lead to the conclusion that salt tests should be designed for specific objectives.

Keywords: sodium chloride test, sodium sulfate test, masonry materials, crystallization kinetics

1. Introduction

It has long been known that laboratory tests have limitations and rarely can reproduce the deterioration induced on building materials over time. Lubelli et al.¹ have recently summarized the shortcoming of these tests and of the mathematical models based on the accepted salt crystallization theories.

The deterioration induced by salt crystallization has been studied for over a century and the present paper aims to point out relevant issues with regards to the most common salts present in monument and structures, such as the high damage inducing sodium sulfate, the ubiquitous sodium chloride, and the less damaging gypsum. Because sodium sulfate induces such fast and intense deterioration in materials, it has been the salt most used for crystallization tests to evaluate mechanical resistance (durability) of materials. However, one of the problems with this test is that the conditions under which it is undertaken strongly influence the results obtained.¹ Therefore, results from different laboratories are practically impossible to compare.

Meanwhile, other crystallization tests have been developed for specific materials, such as the sodium chloride for replacement mortars, and the gypsum efflorescence for evaluation of both brick as well as mortar formulations. Tests with a more focused objective have proven more useful than the generalized sodium sulfate crystallization test.

2. Crystallization tests

2.1. Sodium sulfate (Na_2SO_4)

The oldest salt crystallization test uses a Na_2SO_4 solution to impregnate the samples and then subject them to wet-drying cycles^{2,3} since it can result in intense damage to the substrate. It was used to test durability and mechanical resistance. The deterioration of the substrate can be attributed to the crystal growth that may occur both during the drying as well as the wetting step⁴ and that both thenardite, the anhydrous form, and mirabilite, the decahydrate, can crystallize simultaneously, one at the expense of the other, thus inducing repeated crystallization cycles.⁵

From the study of the actual behavior of salts as they crystallize out, both Püh-ringer⁶ and Zehnder and Arnold⁷ show that crystal size and habit will depend on the relative humidity (or moisture availability) during the crystallization process and strongly related to crystallization kinetics.

Rodríguez Navarro et al.⁸ showed that under normal conditions, i.e., non-equilibrium, 40% RH and 20°C and relative fast evaporation, the anhydrous thenardite will crystallize directly from solution (although it is below the 32.4°C thenardite-mirabilite transition point) inducing significant deterioration to the substrate and thereby also reflecting the importance of crystallization kinetics. Furthermore, no direct hydration of thenardite occurred, with mirabilite being produced only from the dissolution of thenardite and its reprecipitation, as previously shown⁵. For materials with a relatively homogeneous pore system, those with finer pores tend to suffer more deterioration from salt crystallization than those with larger pores. Further studies by Cultrone and Sebastián⁹ confirmed the increase of smaller pores (<1 μm) after salt crystallization tests is possibly caused by

microfissures formation. Benavente et al.¹⁰ characterized material parameters of several different rocks and applied a non-standard Na_2SO_4 crystallization test to determine their resistance to it. Using a principal component analysis they correlated the resulting salt weathering to the pore structure of the stone, its water transport properties, as well as its mechanical strength finding that the latter was the most important parameter in resisting this particular salt weathering in agreement with previous tests carried out on bricks.¹¹ It would appear that this non-standard crystallization test proved to be more useful than the accepted standard test.

2. Sodium chloride (NaCl)

Sodium chloride, halite, is probably one of the most ubiquitous salts originating both from marine environments and the use of deicing salts in northern countries.¹² This salt induces deterioration such as powdering, which is more likely to develop when isometric crystals grow, as observed on Venetian brick shown in *Figure 1* left; or flaking, which in our experience can be attributed to columnar crystals growth as shown on another Venetian brick sample, *Figure 1* right. This particular sample was collected in Venice but only analyzed some years later. As shown in the photomicrograph, initially NaCl formed the cubic crystals, but with the change in environmental conditions (closed sample holder) over years, the slow drying out resulted in the change of habit of the crystal growth following the pattern described by Zehnder and Arnold⁷ and clearly showing that crystals grow from the bottom up.

Sodium chloride is far less damaging than sodium sulfate. When tested in immersion/drying cycles far more cycles are needed to produce damage¹³ than with Na_2SO_4 , even though studies have

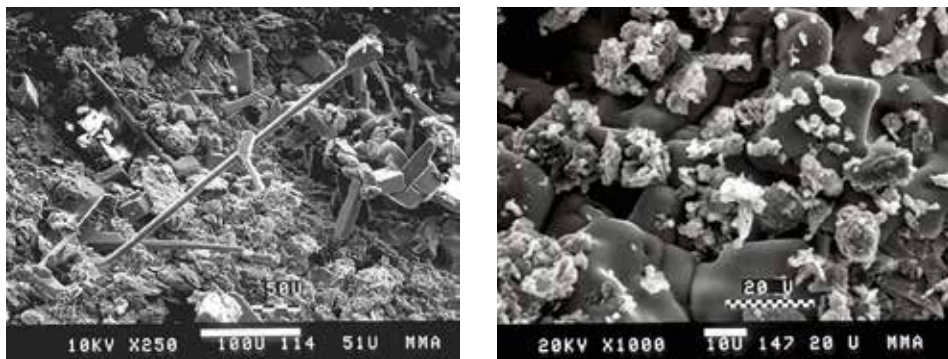

Figure 1: Left: A brick sample collected from the S.Stefano church in Venice and analyzed some years later show the change in crystal growth habit resulting from the changed environmental conditions. Right: Cubic halite crystals growing on brick from the Abbazia da Misericordia in Venice (ca. 1980), where brick powder can be seen being pushed away by the growing crystals.

shown that NaCl also tends to crystallize in smaller pores ($>1\mu\text{m}$).¹⁴ Lubelli¹⁵ presents an overview of salt weathering tests and concludes that sodium chloride crystallization damage is enhanced by repeated dissolution/crystallization cycles induced by fast drying of the moistened sample or by changing RH conditions. Based on these premises, a test¹⁶ that uses this latter approach was developed by Prof. Henriques and his team^{17, 18} to evaluate replacement mortars for historic buildings, so as to ensure that the replacement mortar will be compatible with both the remaining original mortar and the weathered masonry material. The test is briefly described below.

The test¹⁶ uses regular shaped specimens for easy visualization of any changes. The specimens are dried at $105 \pm 5^\circ\text{C}$ for 24 hours and weighed. Once cooled to room temperature they are immersed in a supersaturated solution of sodium chloride at $20\text{-}25^\circ\text{C}$ for 24 hours. They are left to dry for 1 hour and then dried at $105 \pm 5^\circ\text{C}$ until constant weight, i.e., when the weight between two subsequent 24-hour is equal or less than 0.1% of the sample weight. Once this has been achieved, they are cycled in a climate chamber between dry ($<40\%$ RH) and humid ($>90\%$ RH), every 12 hours. After each

cycle, or number of cycles, the samples are weighed and visually evaluated, using the following scale: U unaltered; SD surface disaggregation; HD half disaggregate; and, D disaggregated.

The test has been used extensively and has proved useful, particularly for evaluating restoration mortars for situations where sodium chloride is the main deterioration factor.¹⁸

2.3. Gypsum ($\text{CaSO}_4 \cdot 2\text{H}_2\text{O}$)

Most of the papers dealing with gypsum address the black crusts formed on calcareous stones from air pollution and the deterioration they caused. Fewer papers deal with the efflorescence of gypsum. These are currently considered as being mainly an aesthetic problem, rather than the potential deteriorating agent it will prove to be with time. When in the 1960s the main monuments and buildings in Paris were cleaned of their black crusts using an aggressive sanding procedure, the reaction of the conservation community was that some black crusts could be considered “protective”. It took some years until the phenomenon of black crust formation and its deteriorating effect was clearly understood.

An interesting example of the deterioration that gypsum can induce was reported when a Romanesque mural painting was uncovered in Austria.¹⁹ It had been covered by a thick plaster and had suffered quite some damage in the lower part by rising damp problems. Once uncovered, the mural paintings were desalinated by poulticing. The desalination extracted the more soluble NaCl whose presence significantly increases the solubility of the gypsum.^{20, 21} However, its removal reduces the solubility of the gypsum that started “bloom” lifting up the paint layers. Therefore, further conservation measures were required to stabilize the mural painting.¹⁹

A more prosaic of gypsum efflorescence was found on a brick retaining wall in the garden at the Cowper Hewitt Museum as shown in *Figure 2*. The gypsum, probably found in the soil of the garden on the other side of the wall, migrates solubilized in water (from watering plants and rain) through it and crystallizes out as a white efflorescence at about the top soil level on the garden side.

It is interesting to compare the gypsum crystals formed from direct crystallization with a fairly constant supply of moisture, to those formed by reaction of air pollution with a calcareous material, such as limestone. *Figure 3* shows the well-formed crystal shapes that resulted



Figure 2: Detail of the brick wall showing the gypsum efflorescence formed on the parallel wall below grade to that seen in the garden at right.

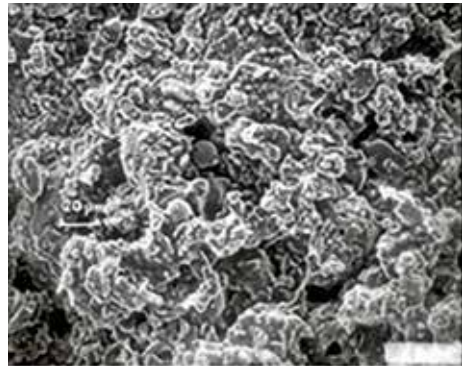

Figure 3: SEM photomicrographs of the gypsum efflorescence on brick, left (see Fig.2 left), and the framboidal growths resulting from air pollution on limestone of the Cowper Hewitt Museum, right.

from growth in the presence of sufficient moisture⁷ and those formed as a result from air pollution reacting with the limestone of the Cowper Hewitt Museum (see Figure 2) with limited moisture, highlighting the importance of crystallization kinetics in producing significantly different crystallization patterns and degrees of deterioration, as discussed elsewhere.⁸ The poorly crystallized gypsum in the black crusts will migrate into the substrate when enough moisture is available for its dissolution. Once in the sub-surface it will re-crystallize into larger and better formed crystals, thus slowly inducing more damage to the material with time as described by Domasłowski.²²

Over the past 35 years, gypsum efflorescence was found to form on new construction in the UK, The Netherlands and Belgium.²³⁻²⁵ The origin of this efflorescence was attributed mainly to the used masonry mortar formulations, mostly ready-to-use based on Ordinary Portland Cement, and containing additives such as air-entrainers, surfactants among others. The development of tests to study this is-

sue was first undertaken by Bowler and collaborators.^{23, 26} However, these tests had several drawbacks as discussed by Chwast²⁷ who then tried to improve the testing procedure, as discussed below.

A wick-test setup (see Figure 4) was adapted to evaluate the risk of gypsum efflorescence formation on brick masonry.²⁷ The test uses a thoroughly desalinated brick core sample ($\varnothing = 30\text{mm}$, height = 62mm) which serves as the transport medium by being kept in constant contact with the test solution (that represents the source of the salt). Evaporation takes place only over the brick core sample promoting continuous efflorescence formation. Gypsum can be found both in brick²³ but also in carbonating cement paste²⁷, so to include this latter source carbonated cement paste, and if desired, mortar admixtures, can be added. For this purpose, both powdered brick and hardened cement paste are added to the solution. The sulfate and Ca^{++} ions migrate then into the brick core and will precipitate efflorescing or subflorescing as gypsum on the drying surface. The ef-

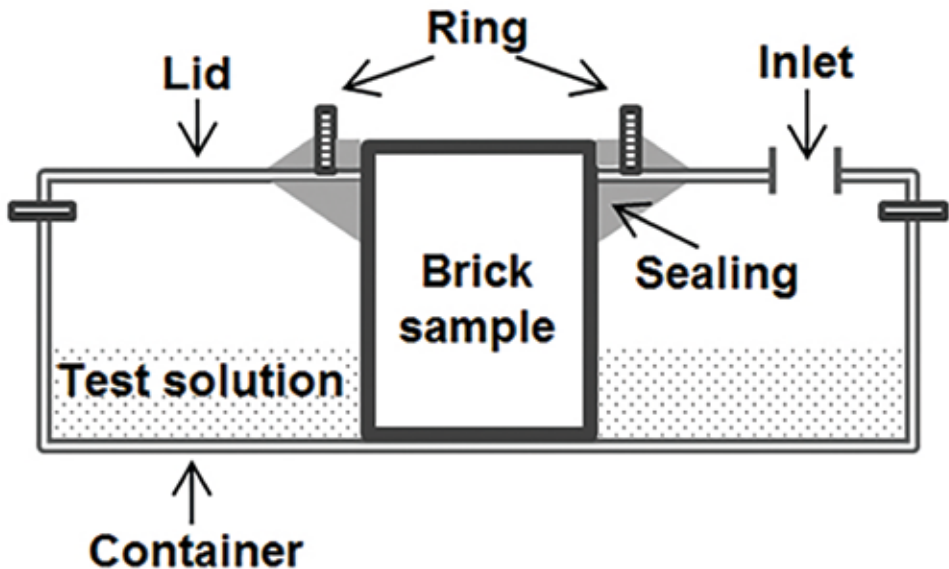

Figure 4: A sketch of the optimized wick-test set up.

fect of admixtures can be evaluated alone (mixed with a gypsum solution), as a component of carbonated cement paste, or added to the brick powder. The amount of the tested sample is calculated to quantitatively reflect the mortar to brick ratio in real masonry. The efflorescence appearance and thus human appreciation of its extent substantially depend on the light conditions and surface dryness. For this reason, high quality efflorescence photographs are collected under well controlled conditions from dry samples allowing for a reliable evaluation of the discoloration extent by means of visual and digital image analysis.

Furthermore, efflorescence composition is determined by XRD and HCl tests, while its effect on the wick performance is evaluated by a drying rate analysis.²⁷

3. Discussion and conclusion

Salts induce deterioration in materials when they migrate into it and crystallize out. Some salts induce far more damage than others, sodium sulfate being the prime example. Therefore it has been used to evaluate material durability. But the durability of a material depends on the material itself as well as on the conditions under which the salt crystallizes. Since the former may be heterogeneous, as is the case for bricks²⁸; and the latter cannot be predicted in practice, the results of standard crystallization tests are not completely reliable.

Sodium chloride will also induce damage, albeit at a slower rate, while gypsum is probably the salt that is slowest in inducing deterioration. Crystallization kinetics will vary depending on environmental conditions; therefore, the same amount of salt will produce different deterioration patterns, which will also depend on the nature of the material. This suggests that the use of a single salt test needs to be specifically developed for a

specific material and cannot be used to evaluate different ones. Finally, the fact that salt distribution in porous materials is not homogeneous²⁹ makes this an even more complex situation.

The above considerations lead to the conclusion that salt tests should be designed for specific objectives, such as the two test examples mentioned for sodium chloride and gypsum. By focusing on the dominating deteriorating effect, as done by Henriques¹⁶, relatively simple tests can be elaborated that will provide the information required. However, the complexity of the salt induced deterioration as outlined above, suggests that it cannot be expected that one single test provide all the information that would be desirable.

References

- ¹Lubelli B., van Hees R.P.J., Nijland T.G., Salt crystallization damage: how realistic are existing ageing tests? 3rd International Conference on Salt Weathering of Buildings and Stone Sculptures, ed. De Clercq H., KIK-IRPA, Royal Institute for Cultural Heritage, Brussels, (2014), 259-273.
- ²Schmölzer A., Zur Entstehung der Verwitterungsskulpturen an Bausteinen. *Chem. Erde* (10), (1936), 479-520.
- ³de Quervain F., Jenny V., Verhalten der Bausteine gegen Witterungseinflüsse in der Schweiz. In *Beiträge zur Geologie der Schweiz, Geotechnische Serie, 30* Lieferung, ed. Schweizerische Geotechnische Kommission, Kümmerly & Frey, Geographischer Verlag, Bern, (1951), 1-66.
- ⁴Steiger M., Asmussen S., Crystallization of sodium sulfate phases in porous

- materials: The phase diagram Na₂SO₄-H₂O and the generation of stress. *Geochimica and Cosmochimica Acta* (72), (2008), 4291-4306.
- ⁵ Charola A.E., Weber J., The hydration-dehydration mechanism of sodium sulphate. In: 7th International Congress on Stone Deterioration and Conservation, eds. Delgado Rodrigues J., Henriques F., F.Telmo Jeremias F., Laboratório Nacional de Engenharia Civil, Lisbon, (1992), 581-590.
- ⁶ Pühringer J., Salt disintegration. Salt migration and degradation by salt – a hypothesis. D15:1983. Swedish Council for Building Research: Stockholm, (1983).
- ⁷ Zehnder K., Arnold A., Crystal growth in salt efflorescence. *Journal of Crystal Growth* (97), (1989), 513-521.
- ⁸ Rodriguez-Navarro C., Doehne E., Sebastian E., How does sodium sulfate crystallize? Implications for the decay and testing of building materials. *Cement and Concrete Research*, (30), (2000), 1527-1534.
- ⁹ Cultrone G., Sebastián E., Laboratory simulation showing the influence of salt efflorescence on the weathering of composite building materials. *Environmental Geology*, (56), (2008), 729-740.
- ¹⁰ Benavente D, Cueto N., Martínez-Martínez J., García del Cura M.A., J.C. Cañaveras J.C., The influence of petrophysical properties on the salt weathering of porous building rocks. *Environmental Geology*, (52), (2007), 215-224.
- ¹¹ Somsiri S., Zsembery S., Ferguson J.A., A study of pore size distributions in fired clay bricks in relation to salt attack resistance. In Proc.7th International Brick Masonry Conference, eds. McNeilly T., Scrivener J.C., eds. University of Melbourne, Melbourne, (1985), 253-260.
- ¹² Lewin S.Z. and Charola A.E., The physical chemistry of deteriorated brick and its impregnation technique. In *Il Mattone di Venezia*. Laboratorio per lo Studio della Dinamica delle Grande Masse del CNR and Università di Venezia, Venice, (1979), 189-214.
- ¹³ Binda L., Baronio G., Charola A.E., Deterioration of porous materials due to salt crystallization under different thermohygrometric conditions. I. Brick. 5th International Congress on Stone Deterioration and Conservation, Félix G., ed. Presses Polytechniques Romandes, Lausanne, (1985), 279-288.
- ¹⁴ Amadori M.L., Lazzarini L., Massa S., Il deterioramento da sodio cloruro di rocce compatte e porose a Venezia. La conservazione dei monumenti nel bacino Mediterraneo. 1st International Symposium 1989, ed. Zezza F., Grafo, Brescia, (1990), 83-89.
- ¹⁵ Lubelli B.A., Sodium chloride damage to porous building materials. Ph.D. Thesis. Technical University of Delft, (2006).
- ¹⁶ Henriques F.M.A., Pedras naturais e artificiais. Análise de argamassas. Determinação da resistência a acção dos cloretos. Universidade Nova de Lisboa, Caparica. (1996), Fe 12.
- ¹⁷ Henriques F.M.A., The effects of soluble salts on a vaulted ceiling. Proc. 7th Int. Congress on Deterioration and Conservation of Stone, eds. Delgado Rodrigues J., Henriques F, Telmo Jeremias F. Laboratório Nacional de Engenharia Civil, Lisbon, (1992), 1355-1362.
- ¹⁸ Faria P., Henriques F.M.A., Rato V., Com-

- parative evaluation of lime mortars for architectural conservation. *Journal of Cultural Heritage*, (9), (2008), 338-346.
- ¹⁹Leitner H., The treatment of wall paintings affected by salts: An interdisciplinary task as seen from a conservator's perspective. *Restoration of Buildings and Monuments*, 11[6] (2005) 365-380, and, *European Research on Cultural Heritage 5, ARCCHIP Workshops*, eds. Simon S., Drdácý M. Institute of Theoretical and Applied Mechanics: Prague (2006), 201-314.
- ²⁰Charola A.E., J.Pühringer J., Steiger M., Gypsum: a review of its role in the deterioration of building materials. *Environmental Geology*, (52), (2007), 339-352.
- ²¹Larsen P.K., The salt decay of medieval bricks at a vault in Brarup Church, Denmark. *Environmental Geology*, (52), (2007), 375-383.
- ²²Domaslowski W. La conservation préventive de la pierre. *Musées et Monuments*, XVIII, UNESCO, Paris, (1982), 51-57.
- ²³Bowler G.K., Winter N.B., Investigation into causes of persistent efflorescence on masonry. *Masonry International*, (11), (1997), 15-18.
- ²⁴Brocken H., Nijland T.G., White efflorescence on brick masonry and concrete masonry blocks, with special emphasis on sulfate efflorescence on concrete blocks. *Construction and Building Materials*, (18), (2004), 315-323.
- ²⁵Chwast J., Todorovic J., Janssen H., Elsen J., Gypsum efflorescence on clay brick masonry: Field survey and literature study. *Construction and Building Materials*, (85), (2015), 57-64.
- ²⁶Bowler G.K., Sharp R.H., Testing of various brick/mortar combinations for mortar durability, efflorescence potential and resistance to rain penetration. *Proc. British Masonry Society*, (1998), 31-36.
- ²⁷Chwast J., Gypsum efflorescence on clay brick masonry. Ph.D. Thesis. KU Leuven, (2017).
- ²⁸Rörig-Dalgaard I., Ottosen L.M., Hansen K.K., Diffusion and electromigration in clay bricks influenced by differences in the pore system resulting from firing. *Construction and Building Materials*, (27), (2012), 390-397.
- ²⁹Arnold A., Zehnder K., *Monitoring Wall Paintings Affected by Soluble Salts. The Conservation of Wall Paintings*, Carter S. ed. The Getty Conservation Institute, Los Angeles, (1991), 103-135.